

A high-angle photograph of a worker in full personal protective equipment (PPE) working on a yellow metal structure, likely a ship's deck or a large industrial platform. The worker is wearing a white hard hat, a red and high-visibility yellow safety vest over a tan shirt, and grey work gloves. One glove has 'MADA' and other technical specifications printed on it. The worker is holding a rope or cable. The background shows the blue-green water of the sea.

SFS

Vertical Fall Protection Systems Installation Manual

Contents

| | |
|---|----|
| Introduction | 3 |
| Recognised installers | 4 |
| Conformity | 4 |
| Design and use parameters | 4 |
| Component list | 5 |
| PPE | 6 |
| Installation | 6 |
| Tool list | 6 |
| Specialist tools required | 6 |
| Installation guide | 7 |
| Termination swaging/crimping | 8 |
| Tensioning | 10 |
| System tagging | 11 |
| Annual maintenance and Recertification | 12 |
| O&M/User instructions | 13 |
| Warranty | 13 |
| Testing standards | 14 |
| References | 14 |

Introduction

This guide has been compiled to ensure that the correct installation of Vertical Lifeline systems is adhered to at all times.

The installer should have previous Vertical Lifeline installation knowledge, design understanding and have taken part in SFS training.

It is important that the installer fully understands this guide before commencement of installation on site.

Vertical Lifeline systems are designed to act as a fall prevention method, or as a means of minimising the consequences of a fall, should it occur.

Only trained personnel should be involved in the design, correct installation, and recertification of Vertical Lifeline systems. Failure to follow this guide could put people's lives at risk.

It is imperative that the correct components are used for the specific application, and any doubts should be resolved by seeking guidance from SFS Fall Protection.



Recognised installers

Only competent installers trained by SFS are certified to carry out installation and re-certification of the Vertical Lifeline system.

Recognised installers should ensure their personnel on site are competent and trained to the standards expected by SFS.

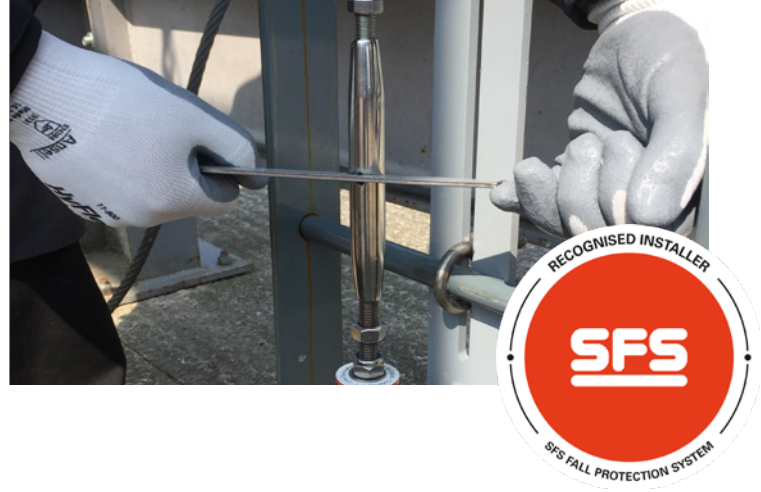

Conformity

SFS Vertical Lifeline systems are a series of fabricated stainless steel anchor points and intermediate brackets secured to fixed ladders, joined through a series of components to create a system using either a 7x7x8mm or 1x19x8mm stainless steel wire cable. Tested by SATRA to EN353-1:2014+(A1 2017).

The 'system' refers to SFS Fall Protection components and wire, none of which should be substituted by non-approved components, modified, or altered without the prior consent of SFS. Systems should not be dismantled or tampered with, as doing so could alter the performance of the system and invalidate its certification which could result in serious injury or death.

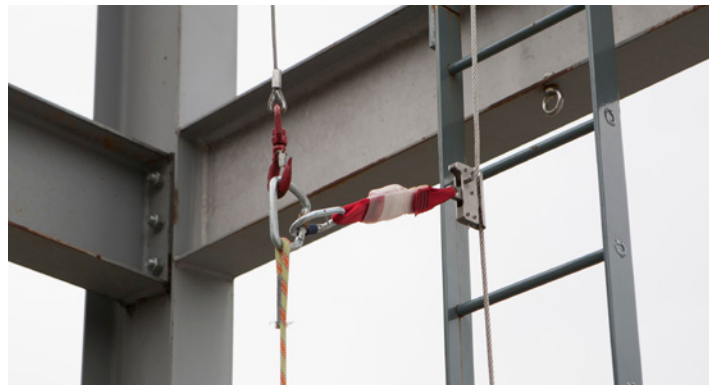

Design and use parameters

The SFS Vertical Lifeline System has been tested in accordance with EN353-1:2014+(A1 2017) for one user (between 70-100kg in weight including tools) and can be fitted to a variety of ladder/rung types and lengths.

We advise that vertical systems should only be fitted to ladders without cages, as these can impede the system from arresting a user's fall.

Lines should have rest points for the user between every 9-12 metres.

SFS Vertical systems should only be used with the SFS vertical device with in-built shock absorber.

- One user system
- Line lengths up to 200m
- 7x7x8mm or 1x19x8mm wire
- Intermediate brackets should be used on system lengths greater than 6m to prevent wind chatter
- Brackets will fit ladder rung sizes between 25-40mm

Component list

| SFS Code | Part # | Description | Image |
|----------|---------|---|-------|
| FP-VS-UL | 1501229 | Extended Upper Ladder Mounting Bracket | |
| FP-VS-LL | 1501230 | Standard Ladder Bracket | |
| FP-VS-IB | 1607550 | Standard Intermediate Bracket | |
| FP-LT-D | 1501205 | 0.8kN Combined Line Tensioner & Indicating Disc for 7x7x8mm | |
| FP-AC-TF | 1520785 | Toggle Fork | |
| FP-VS-AT | 1501242 | Vertical Traveller Device | |

PPE

Only SFS Vertical Traveller device complete with shock absorber should be used with the Vertical system, together

with an approved full body harness complete with front D-Ring attachment.

Vertical Traveller device



Full body harness

Conforming to EN361



Installation

Tool list

- 17mm spanner/wrench
- 19mm spanner/wrench
- 2 x pairs of mole/vice grips
- Marker pen
- Tape measure
- Knife
- Cembre 130kN Hydraulic swager/crimper
- Cembre Hydraulic wire cutters

Specialist tools required

Hydraulic wire cutter for 8mm stainless wire



130kN Hydraulic swager for 8mm stainless wire



Installation guide

1. Upper extended or standard mounting brackets to be installed to appropriate ladder rungs.

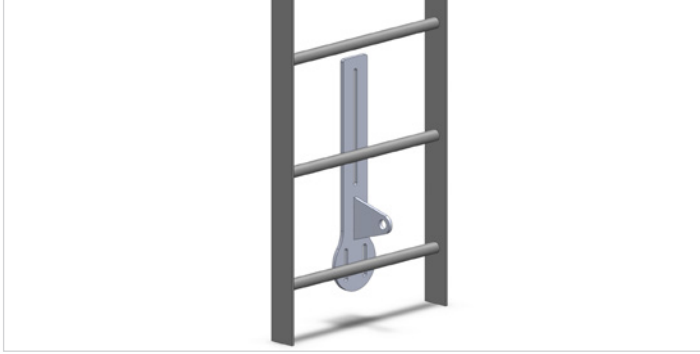

2. Attach with the U clamps provided and torque to 42Nm.



3. Intermediate brackets to be installed at a maximum distance of 6m. (Brackets should be set at unequal spacings to prevent harmonic oscillation.)

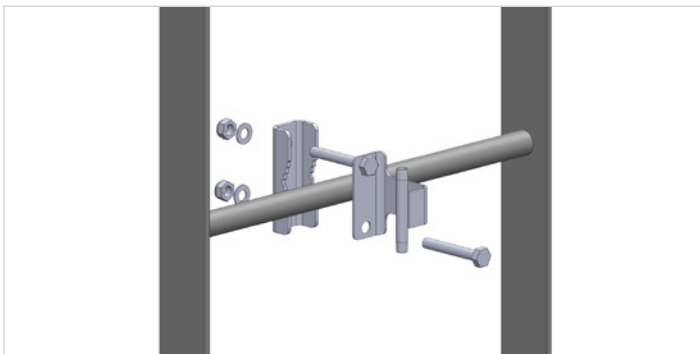

4. Swage/crimp the end toggle to wire and mount bracket.



5. Descend the ladder passing the wire through any intermediate bracket.

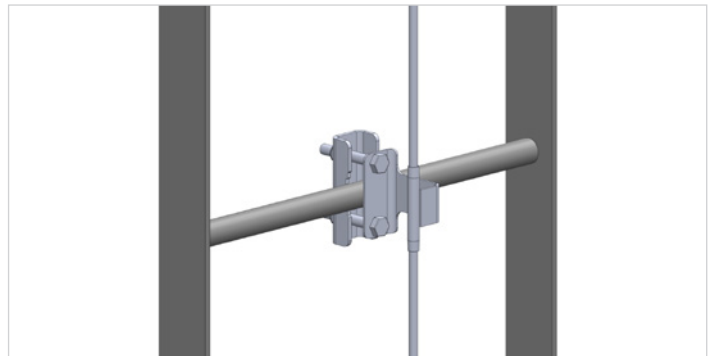

6. Cut, swage and tension wire to appropriate length as detailed on page 8.

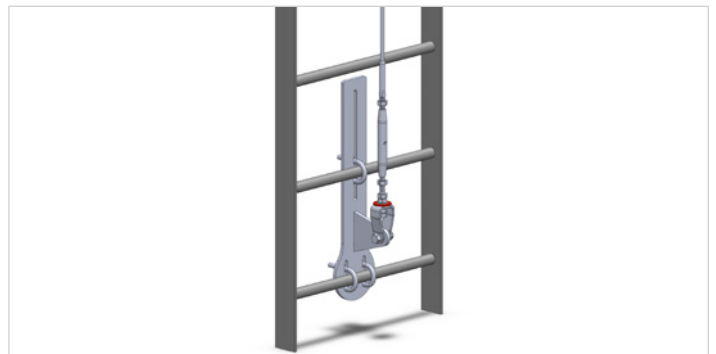

Termination swaging/crimping

1. Take the combined tensioner/line tensioner and fully unwind both ends from the central barrel first. Then wind both back in, two full turns. This maximises the amount of tension it can take up.

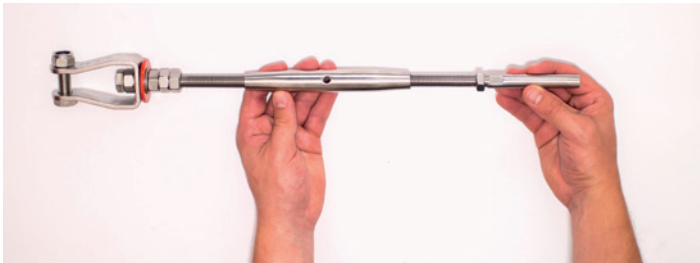

2. Fit the tensioner to the start component loosely, and whilst pulling the wire taught, mark the wire with a marker pen against the pressing on the tensioner. You can now cut the wire on the marking with the Cembre HT-TC026 hydraulic cutter. This will ensure the wire is cut correctly.

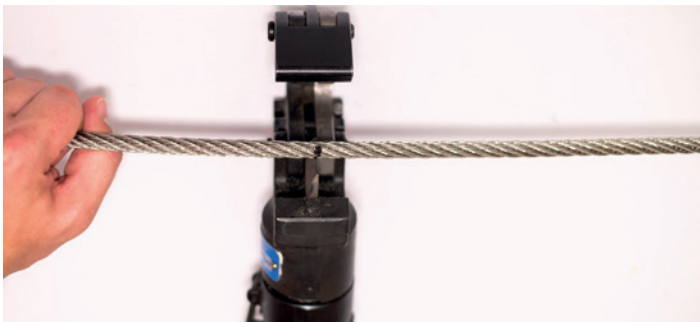

3. As the wire is now cut to the correct length, the tensioner can be removed from the start component ready for crimping/swaging.

4. Insert the wire into the termination fully, and mark the wire at the end of the termination.



5. Remove the wire and place alongside the termination up to the point just marked.



6. Now mark on the termination where the wire ends. This shows where the hollow part of the termination ends, and where the first crimp will be located. This needs to be done on all terminations - tensioners and toggle fork ends.



7. Re-insert the wire fully ensuring the wire is fully engaged in the termination up to the point marked.



8. Take the Cembre HT-131-C crimping tool and set the barrel to 'close'.



9. Position the central section of the die so that the first crimp is made next to the line marked on the termination itself.

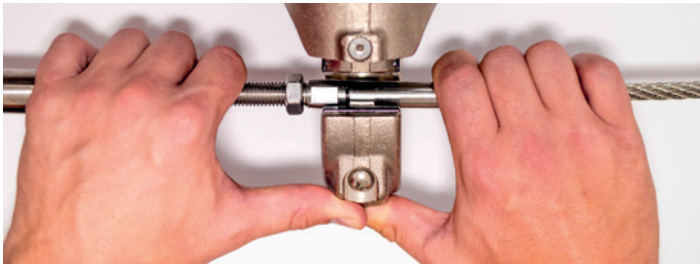

10. During the first crimp ensure that the wire is held into position so that it doesn't slip. Pump the handle on the crimper until a distinctive 'click' is heard and pressure is released from the crimper.



11. Turn the crimper barrel to 'open', pump the handle once to release the jaws.



12. Remove the termination and check that the crimp has been fully pressed and is stamped A10. This shows that the crimp has been properly performed and the die itself is not worn.



13. Moving down the termination, four more crimps need to be performed, ensuring there is a 1mm gap between each. It is also advised to turn the termination after each crimp so that they are not pressed in the same plane which will prevent the termination from slightly bending.

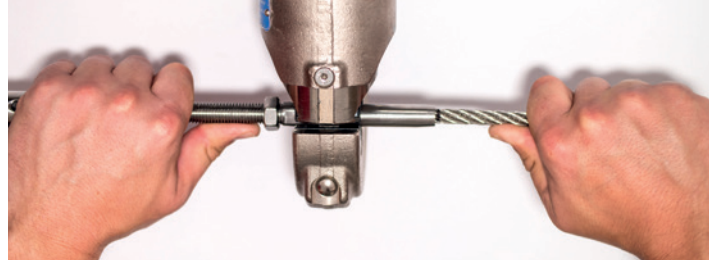

14. All five crimps must be completed on the straight shank hollow section of the termination, and before the chamfered end. Each crimp should show the A10 stamp clearly and not overlap.



15. The termination has now been fully crimped and can be connected to the post by removing the pin/bolt and securing to the start/end post.

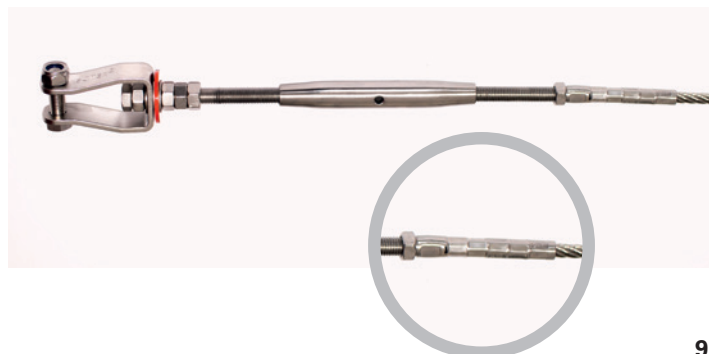

Tensioning

1. To assist with wire tensioning, pull the wire through any intermediate bracket and clamp off on the lowest bracket.



4. Once the required amount of tension has been achieved the white tension indicating disc (marked 0.8kN) will loosen and spin freely.*



2. Once the combined line tensioner termination has been fully crimped it can be properly secured to the ladder mounting bracket, tightening the bolt until it protrudes through the nyloc part of the nut by a minimum of two threads.



5. The nuts on the tensioner can now be tightened against the turnbuckle, locking it in place. All system components should be checked, ensuring all are secure and nothing has been missed.



3. By holding the crimped barrel and line in one hand the turnbuckle/central barrel of the tensioner can be turned, tensioning the line with the other hand.



* Note

Although this indicates the required amount of tension has been achieved, it is the installer's responsibility to check each span has enough tension in it and the tension is evenly distributed throughout the system.

System tagging

It is important that all installed systems are fitted with a certification tag at the point of access, similar to the tag shown opposite, conforming to BS EN 365:2004

The certification tag should include the following information to support the more detailed O&M Manual:

- Contract number/name so that the system can be identified
- System type - restraint/arrest
- PPE Requirements for the user to use the system safely & correctly
- Installation date
- Recertification/inspection due by date

If the recertification date has lapsed, the system **should not be used** until a recognised installer has recertified the system as fit for use.

Systems are required to be recertified annually.

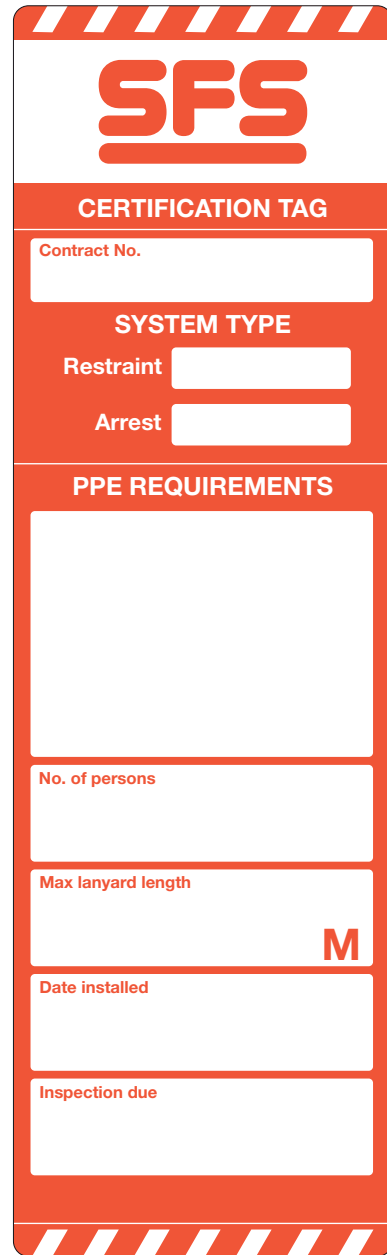

SFS

CERTIFICATION TAG

Contract No.

SYSTEM TYPE

Restraint

Arrest

PPE REQUIREMENTS

No. of persons

Max lanyard length **M**

Date installed

Inspection due

Annual maintenance and Recertification

General notes

Safety line systems must be inspected and recertified at intervals not exceeding twelve months.

Vertical systems are affected by changes of temperature; this will result in expansion/contraction of the wire. Where systems are subject to significant seasonal temperature variations, these will require retensioning for summer and winter operation.

Only those components manufactured and supplied by SFS are permitted for use. The exceptions to this are bespoke fittings required to attach the system to particular structures. Wherever possible such bespoke fittings should be designed and manufactured by SFS, or their design approved. Where such bespoke fittings are provided from another source, it is the installer company's responsibility to ensure they are fit for the purpose intended and carry the necessary approvals.

Under no circumstances must a standard SFS component be modified or replaced by components from another source.

It is important that all devices will align themselves correctly through all componentry; and that there are no obstructions or structures that interfere with the device, or deflect the wires path.

The structure to which SFS Fall Protection systems are to be installed should be sufficiently strong to withstand the fall arrest/restraint loadings for which the system is designed. These loadings can be calculated by the installer or provided by SFS. If there is any doubt as to the structure's ability to withstand such loadings, then the system should not be installed without appropriate testing on the substrate.

Inspection procedure

VISUAL INSPECTION OF COMPLETE SYSTEM

- Check for obvious damage
- Chemical contamination
- Loose fittings
- Building modifications that have resulted in reduced free fall distance/clearance
- Cable damage, paying particular attention to wire passing through any bracketry
- Excessively loose cable

CHECKING OF INDIVIDUAL COMPONENTS

- Components should be secure and tightened to 42Nm.
- Damaged components should be replaced and a careful inspection of any wire passing through the damaged parts is required.

Wire

- 7x7x8mm Stainless Steel cable (minimum breaking load 38kN).
- Visually examine cable, intermediate and end anchorages. The cable must be replaced if there are any signs of damage (kinks, fretting, etc.).
- All systems to be properly tensioned and as such must incorporate a SFS supplied line tensioner and tension disc indicator.
- Correct pretension is achieved when the line tensioner disc spins freely. **Never over tension a system.**

Swaging

- Cable swaging should be accomplished by use of 6mm hexagonal form dies using 5 continuous 'bites.'
- **Note:** the 6mm dimension refers to the width of each face. The across flat dimension, after swaging, is typically 11mm.
- Testing swage joints is possible with specialist equipment from Hydrajaws Ltd. www.hydrajaws.co.uk or Tel. 01675 430370.
- Fittings should be tested to 15kN for 7x7x8mm stainless wire.
- Maintain the applied load for 1 minute and then release.
- Thoroughly examine the following:
 - All swaged connections for 'slip'
 - All components for damage
 - End & Intermediate anchorages for damage/slip
 - The cable for damage
- Test all system terminations and in-line swaged joints.
- Care must be taken when using cable grip devices, so that damage to the cable does not occur and that there are no loads transmitted to the intermediate anchorages.

Operation and maintenance/ User instructions

It is imperative that any safety line system, once installed, is accompanied by a full O&M, and user instruction manual. This manual should be given to the building owner.

Any operative who is to use the system should have access to this document, allowing them to understand how it can be used safely, but also kept in good condition, and recertified at correct intervals.

O&M Manual should detail the following:

- Site location, building name, and reference/location of line
- Installation certificate including installation date and recertification due date
- Contact details of approved company who installed the line
- System layouts
- The purpose or areas in which the system will allow access to
- Recommended PPE to be worn
- User equipment detailed ensuring safe use
- System type - restraint/arrest
- Rescue plan in event of a fall
- Number of persons the system is designed for
- Access point
- Usage/record card
- General safe use and good practice
- Connection of travelling device
- Inspection and maintenance records

Warranty

All Fall Protection products sold within the SFS group carry a standard 12 month 'fit for purpose' product warranty*

In cases where customers seek additional comfort, an extended warranty can be applied for.* This should be done by the system installer within the first 3 months of installation.

Warranty terms may be 1-24 years, or even longer than this, subject to conditions and project specification.

A pre-contract questionnaire, covering building use & proximity to chemicals or coastal environments will be required.

All warranties are subject to the frequency of inspections and system recertification by a recognised SFS Fall Protection system installer.

The Fall Protection range is made from non-ferrous and stainless-steel components, it carries a design life which goes beyond that of the actual building.

Standard terms and conditions covered by our insurers is available on request.

*terms and conditions apply

Testing standards

All SFS Fall Protection products are tested to, and pass, all the relevant and recognised industry standards for each type.

The vertical lifeline system passes EN353-1:2011+(AI 2017). The vertical traveller device carries the CE mark.

All tests have been witnessed and certified by independent testing body SATRA. These tests have been carried out both at SFS's testing facility, and at SATRA's own facility.

References

| | |
|-----------------------------|---|
| BS EN 795:2012 Type A | Anchor device with one or more stationary anchor points while in use, and with the need for a structural anchor(s) or fixing element(s) to fix to the structure |
| BS EN 795:2012 Type C | Protection against falls from height Single User (anchor devices employing a flexible anchor line which deviates from the horizontal by not more than 15°) |
| BS 7883: 2005 | Code of practice for the design, selection, installation, use and maintenance of anchor devices conforming to BS EN 795 |
| BS 8610:2016 | Personal Fall Protection equipment anchor systems |
| CE 0321 EN 795:1996 Class B | Travelling device CE marking |
| EN ISO 9227 | Salt Spray Corrosion Test for CE |
| EN 361:2002 | Full Body Safety Harness |
| EN 362:2002 | Karabiners/connectors |
| EN 355:2002 | Lanyard Shock Absorbers |
| EN 354:2002 | Fall Arrest Lanyards |
| BS EN 365:2004 | Instructions for marking products with user instructions, inspection periods and re-testing |
| ISO 9001 | International standard that specifies requirements for a quality management system (QMS) |
| EN 353-1:2014 | Guided type fall arresters including an anchor line |

